

## VERIFICATION OF COHERENT SPINOR ROTATION OF FERMIONS <sup>☆</sup>

H. RAUCH, A. ZEILINGER, G. BADUREK, A. WILFING

*Atominstytut der Oesterreichischen Hochschulen, A-1020 Wien, Austria*

W. BAUSPIESS

*Institut für Physik, Universität, D-46 Dortmund 50, Germany  
and Institut Laue-Langevin, F-38042 Grenoble, France*

U. BONSE

*Institut für Physik, Universität, D-46 Dortmund 50, Germany*

Received 15 August 1975

The perfect crystal neutron interferometer was used to test the spinor rotation of spin-1/2-systems. Coherently splitted unpolarized slow neutrons exposed partially to a variable magnetic field show interference oscillations which are consistent with the predicted  $4\pi$ -value.

A spinor describing the transformation of a wave function during rotation changes its sign when being rotated by an angle of  $2\pi$  ( $|\pm\rangle' = \exp(-i\sigma\alpha/2)|\pm\rangle$ ,  $\sigma$  are Pauli matrices). As observables in quantum theory are quadratic in the wave function, the change of sign cannot be detected by ordinary experiments. Nevertheless, there exists some discussion in the literature on the observation of this effect. The first Gedanken experiments were published by Aharanov and Susskind [1] and by Bernstein [2]. Further suggestions for an experimental verification with neutron or electron interferometers are notices in literature [3-5], but up to now no successful measurement of this effect has been done.

The perfect crystal neutron interferometer [6, 7] with two widely separated coherent beams (I, II) gives the opportunity to verify this effect. For the beam in forward direction (0) behind the interferometer, there exists a phase shift between the two partial beams as soon as a material with an index of refraction  $n$  and a thickness  $D$  is inserted into beam I. The ratio of the two wave functions is given according to:

$$\psi_0^I / \psi_0^{II} = \exp(-ik(n-1)D).$$

Due to the magnetic coupling of the magnetic moment ( $\mu$ ) of the neutron to a magnetic field ( $B$ ) ( $V = -\mu\sigma B$ ) there exists a different index of refraction for the two spin components:

$$n \approx 1 - V/2E = 1 \pm m\mu B/\hbar^2 k^2.$$

In a magnetic field the neutrons perform the Larmor-precession with a frequency of:  $\omega_L = \gamma B$  ( $\gamma = 2\mu/\hbar$ : gyromagnetic ratio of the neutron). The angle of rotation in a magnetic field can be written as:

$$\alpha = \gamma \int B dt = (\gamma/v) \int B ds = (2\mu m/\hbar^2 k) \int B ds.$$

Separating the wave function into the two spinor components (e.g.,  $\psi_0^I = +\psi_0^I + -\psi_0^I$ ) one obtains:

<sup>☆</sup> Research supported partially by Fonds zur Foerderung der Wissenschaftlichen Forschung - Projekt 1178.

$$\begin{pmatrix} +\psi_o^I(\alpha) \\ -\psi_o^I(\alpha) \end{pmatrix} = \begin{pmatrix} \exp(i\alpha/2) & 0 \\ 0 & \exp(-i\alpha/2) \end{pmatrix} \begin{pmatrix} +\psi_o^I(0) \\ -\psi_o^I(0) \end{pmatrix}$$

This equation reflects the fact that a spinor changes its sign under a  $2\pi$  rotation. Calculation of the intensity of the forward beam of the neutron interferometer with a magnetic field in beam I yields:

$$\frac{I_o(\alpha)}{I_o(0)} = \frac{|\psi_o^I(\alpha) + \psi_o^{II}(0)|^2 + |-\psi_o^I(\alpha) + \psi_o^{II}(0)|^2}{|\psi_o^I(0) + \psi_o^{II}(0)|^2 + |-\psi_o^I(0) + \psi_o^{II}(0)|^2} = \frac{1 + \cos(\alpha/2)}{2}$$

This intensity oscillation can be observed. For neutrons with a wavelength of 1.82 Å, a  $2\pi$  rotation requires a magnetic field which gives  $\int B ds = 74.5$  G cm and a  $4\pi$  rotation needs  $\int B ds = 149$  G cm, respectively.

The perfect crystal interferometer [6, 7] now placed at one guide tube of the HFR-reactor in Grenoble, was used to verify the coherent spinor rotation. Unpolarized neutrons with a wavelength of  $1.82 \pm 0.01$  Å and a beam cross section of  $8 \times 1$  mm were used. They are coherently split into beams I and II, and exposed to various magnetic fields along their paths (see fig. 1). An electromagnet with a pole gap of 10 mm and a face of  $15 \times 15$  mm was used. The magnetic field along the whole flight path of the neutrons is measured with a Hall probe giving

$$\int B ds(\text{path II}) / \int B ds(\text{path I}) = 0.30$$

for the z-component. All other components are smaller than 5% of the z-component in beam I, and smaller than 8% along path II.

Intensity oscillations of the 0- and H-beam were observed while varying the magnetic field (fig. 2). The meas-

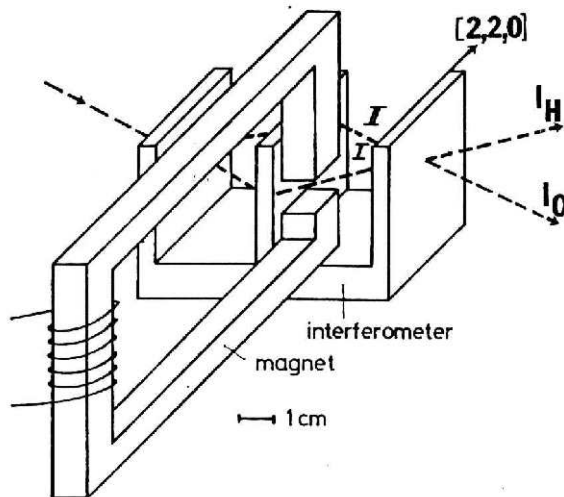

Fig. 1. Sketch of the experimental setup.

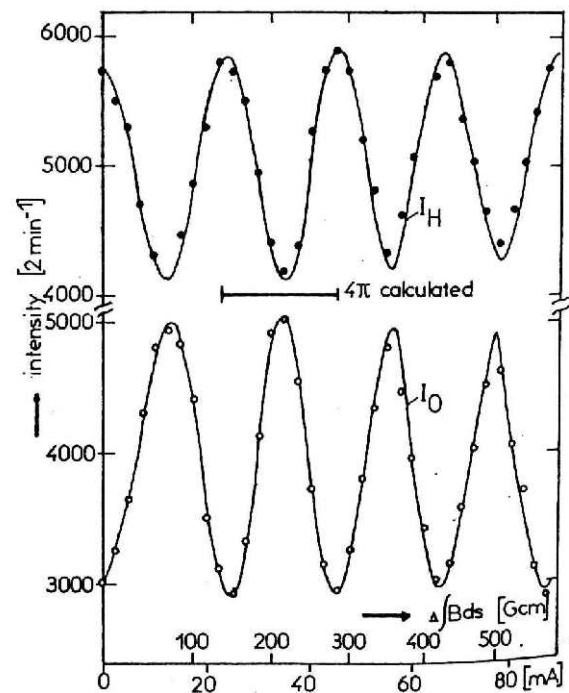

Fig. 2. Observed intensity oscillations of the 0- and H-beam as a function of the difference of the magnetic field action on beam I and II ( $\Delta \int B ds = \int B_z ds(\text{path I}) - \int B_z ds(\text{path II})$ ).

ured period was  $(144 \pm 8)$  G cm, corresponding to a rotation angle of  $(704 \pm 38)$  deg. The uncertainty is mainly caused by the magnetic field determination along path I and II.

The oscillation period clearly shows that the identical wave function is reproduced after a spinor rotation of  $4\pi$  and a  $-1$  occurs for a  $2\pi$  rotation.

We thank Doz. E. Balcar and Professor G. Eder for many helpful discussions.

## References

- [1] Y. Aharonov and L. Susskind, Phys. Rev. 158 (1967) 1237.
- [2] H. Bernstein, Phys. Rev. Lett. 18 (1967) 1102.
- [3] G.T. Moore, Am. J. Phys. 38 (1970) 1177.
- [4] A.G. Klein and G.I. Opat, Phys. Rev. D11 (1975) 523.
- [5] M.A. Horne and A. Shimony, private communication.
- [6] H. Rauch, W. Treimer and U. Bonse, Phys. Lett. 47A (1974) 369.
- [7] W. Bauspiess, U. Bonse, H. Rauch and W. Treimer, Z. Physik 271 (1974) 177.